



USB-i485 Converter

RS485/RS422



INSTRUCTION MANUAL V1.0x H



1.	SAFETY ALERTS	3
2.	PRESENTATION	4
3.	DIMENSION	5
4.	USB DRIVER INSTALLATION	6
4.1	WINDOWS	6
4.2	LINUX.....	6
4.3	MAC.....	6
5.	SERIAL PORT (COM PORT) ASSIGNMENT - WINDOWS.....	7
5.1	DETERMINATION	7
5.2	SELECTION.....	7
5.3	IMPORTANT RECOMMENDATION	8
6.	CONNECTIONS.....	9
6.1	HALF-DUPLEX RS485 HALF-DUPLEX (2 WIRES).....	9
6.2	FULL-DUPLEX RS485 FULL-DUPLEX (4 WIRES).....	10
6.3	RS422.....	10
7.	LED OPERATIION.....	11
8.	CONFLICTS WITH OTHER USB DEVICES IN WINDOWS.....	12
9.	TECHNICAL SPECIFICATIONS	13
9.1	CERTIFICATIONS	13
10.	WARRANTY	14

1. SAFETY ALERTS

The symbols below are used in the device and throughout this manual to draw the user's attention to important information related to device safety and use.

		
CAUTION Read the manual fully before installing and operating the device.	CAUTION OR HAZARD Risk of electric shock.	ATTENTION Material sensitive to static charge. Check precautions before handling.

All safety recommendations appearing in this manual must be followed to ensure personal safety and prevent damage to the instrument or system. If the instrument is used in a manner other than that specified in this manual, the device's safety protections may not be effective.

2. PRESENTATION

USB-i485 Converter is a cost-effective way to convert RS485 or RS422 industrial buses to a USB interface. By connecting the **USB-i485 Converter** to a computer USB port, it will be automatically detected and installed as a native COM port, compatible with any existing serial communication application.

Multiple converters can be installed when using USB hubs, allowing you to easily set up a multi-serial system without any worries about IRQ or DMA settings.

1500 Vdc galvanic isolation between the USB port and RS485/RS422 protects the computer from spikes or possible misconnections in the communication bus.

USB-i485 Converter can be configured for RS422, 4-wire RS485 (Full Duplex), or 2-wire RS485 (Half Duplex) networks. When operating in 2-wire RS485, the data transfer control is automatically controlled by the converter. Two 2-wire RS485 networks can be connected to the converter, thus duplicating the possible number of remote devices.

3. DIMENSIONS

USB-i485 Converter has the following dimensions:

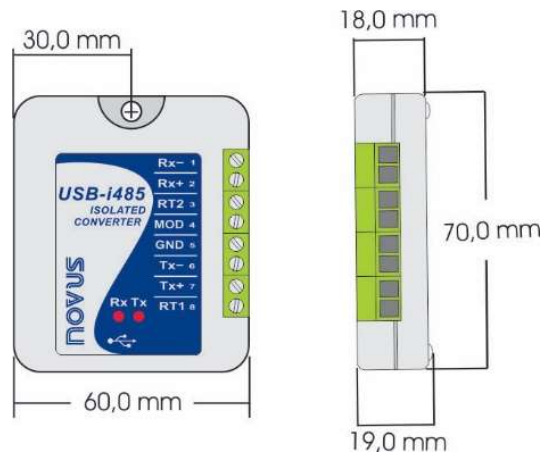

Figure 1 - Dimensions

4. USB DRIVER INSTALLATION

The installation steps shown may vary from computer to computer or even between operating system versions. The steps shown below are guidelines only.

4.1 WINDOWS

- a) Run the driver file available on our website.
- b) Connect the converter to the computer USB port. Windows will detect the new hardware and automatically try to proceed with the installation.
- c) After a few seconds, an installation error message will be displayed on the bottom right corner of the screen. This error is because Windows does not recognize any drivers that have not been previously registered with Microsoft.
- d) Open the Device Manager screen and search for the "F232R USB UART" device in the "Other Devices" category. Double-click it and click on the "Update Driver..." button.
- e) Choose the "Browse my computer for driver software" option.
- f) Select the "Drivers\Windows" folder. Leave the "Include subfolders" option checked.
- g) After a few moments, a window will appear, asking if you want to install this device software. Select the "Install" option.
- h) Wait a few more seconds. A window displaying the installation success will be shown.

4.2 LINUX

Since version 2.4.20, the kernel already includes the driver needed for the converter to work.

Once you connect the converter to the computer, the following modules should be loaded (they must be in the kernel module list):

- `ftdi_sio` (specific driver of the converter);
- `usbserial` (generic driver for USB-Serial conversion);
- `usbcore` (basic driver for USB devices).

4.3 MAC

See the documentation on the device page of our website. The *Virtual Driver COM* file provides information about how to perform the installation.

5. SERIAL PORT (COM PORT) ASSIGNMENT - WINDOWS

5.1 DETERMINATION

The serial port associated to the **USB-i485 Converter** is automatically determined by the operational system a few moments after the device is connected. By accessing the Windows Device Manager, you can identify or change the COM port associated with the **USB-i485 Converter**:

Control Panel → **System** → **Hardware** → **Device Manager** → **COM & LPT Ports**

You can also open the Device Manager by running the following command: "devmgmt.msc".

After opening the Device Manager, you can check the Serial Port (COM) associated to the **USB-i485 Converter**. As it can be seen in the figure below, the **USB-i485 Converter** is associated to COM7:

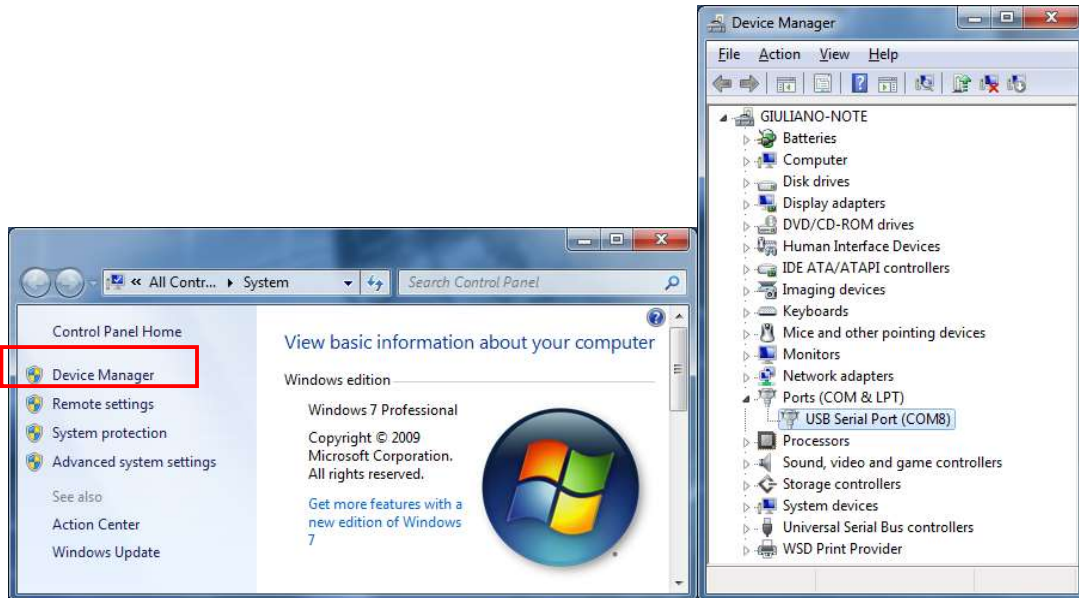

Figure 2 – COM Port Determination

5.2 SELECTION

If you need to change the Serial Port (COM) associated with the **USB-i485 Converter**, select the "USB Serial Port (COM X)" of the **USB-i485 Converter**. Go to "Action/Properties" and, on the "Port Settings" tab, click on **Advanced**, as shown in **Figure 03**. If this tab does not appear, it means that the driver was not installed correctly. Therefore, you will need to reinstall the configurator software.

In the "Advanced Settings for COMX" window, change the "COM Port Number" parameter to the desired COM, as shown in **Figure 04**. Some serial ports may be marked as "In Use". Only select one of these ports if you are sure that it is not in use by another computer device.

In some situations, serial ports may be marked as in use even when the associated device is no longer installed on the computer. In this case it is safe to associate them to the **USB-i485 Converter**.

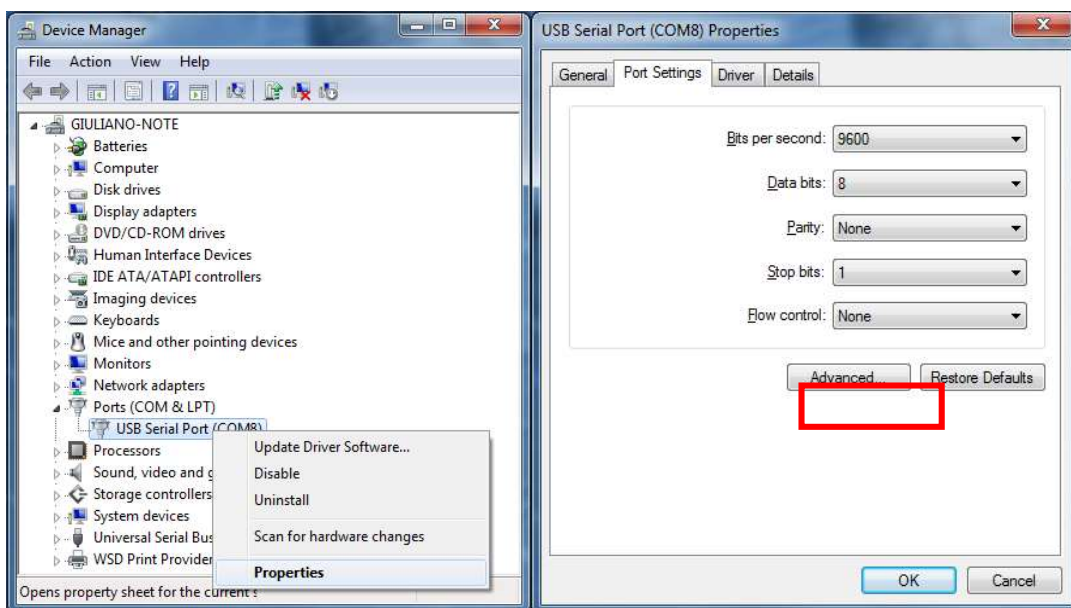

Figure 3 – Accessing the COM port advanced configuration

5.3 IMPORTANT RECOMMENDATION

To improve the USB interface communication, it is recommended to configure the “Latency Timer”. This parameter can be modified by accessing the “Advanced Settings for COMX” window, as shown in **Figure 03**.

Afterwards, you can check, as shown in **Figure 04**, the “Latency Timer (ms)” parameter, which must be changed to 4:

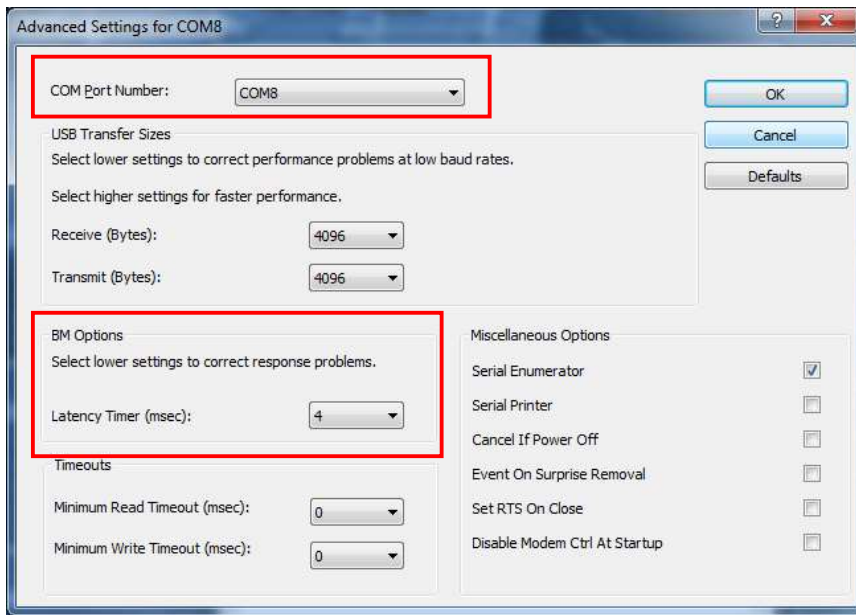

Figure 4 – Advanced settings for COM

6. CONNECTIONS

The appropriate connection to the **USB-i485 Converter** depends on the type of serial network: RS422, 2-wire RS485 or 4-wire RS485. The following figure shows a description of all **USB-i485 Converter** connection terminals:

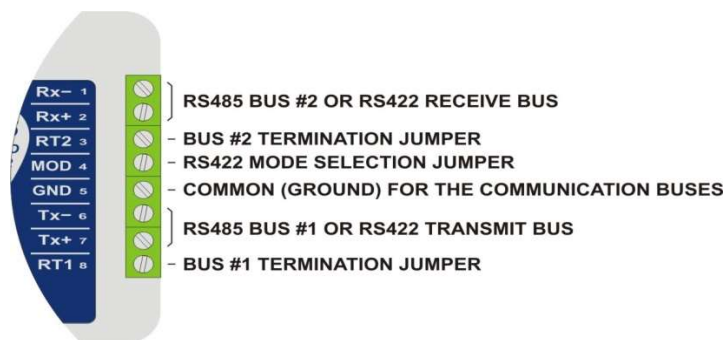

Figure 5 – Device Connections

A shielded twisted-pairs cable is recommended for wiring the communication bus from the converter to all network devices. The shield should be grounded and/or connected to the common terminals of all devices. The minimum recommended wire gauge is 24 AWG (0,2 mm²).



It is highly recommended that you use an additional conductor to interconnect the common terminal of the network devices.

If this recommendation is not followed, communication circuits of one or more devices on the network may be damaged.

RS485 or RS422 devices from different vendors or of different models may identify the communication terminals using distinct notation. The following table shows some of this notations and its equivalence to the **USB-i485 Converter**.

USB-i485 CONNECTION IDENTIFICATION	Rx+ ou Tx+	Rx- ou Tx-
POPULAR RS485 AND RS422 CONNECTION IDENTIFICATION	D	\bar{D}
	D1	D0
	B	A
	D+	D-

Table 1 – Identification

6.1 RS485 HALF DUPLEX (2-WIRE)

To set this mode of operation, the MOD terminal (pin 4) must be left unconnected.

This is the usual RS485 connection. A single twisted pair is used for data transmission and reception. Multiple RS485 devices are connected in a single bus, as shown in the next figure. Devices from different vendors may use different names for the data signal terminals.

In the following figure, different identification schemes are presented for each device, with the proper connection to the **USB-i485 Converter**. RS485 devices can be connected to either bus 1 or 2.

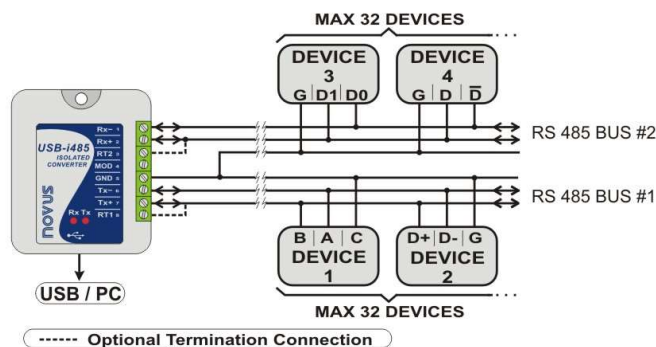

Figure 6 – Half Duplex RS485 (2-wire)

To ensure voltage balance between the devices, the common terminal (GND - pin 5) must be connected to the corresponding terminals of each device. If the common conductor is not installed between all devices, they should be grounded according to the manufacturer's recommendations. In this case you should ground the common terminal (GND - pin 5) of the converter.

The need to use termination resistors depends on the total length of the communication bus and the communication speed configured.

USB-i485 Converter has internal termination resistors, which can be connected by including the dotted connections shown in the figure above.

For more information on termination resistors, see the document *RS485 and RS422 Basic Concepts*, available on our website www.novusautomation.com.

6.2 RS485 FULL DUPLEX (4-WIRE)

To set this mode of operation, the MOD terminal (pin 4) must be connected to the GND terminal (pin 5).

In this mode, two pairs of wires are used for communication. Data from the **USB-i485 Converter** to the networked devices are transmitted through one pair, and the other pair carries data from the devices to the **USB-i485 Converter**.

Multiple devices are connected, as shown in the figure below:

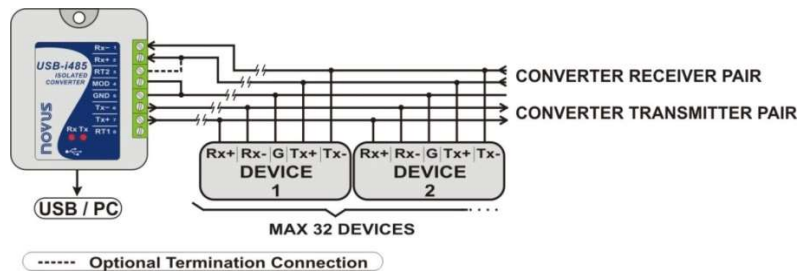

Figure 7 – Full Duplex RS485 (4-wire)

To ensure voltage balance between the devices, the common terminal (GND - pin 5) must be connected to the corresponding terminals of each device. If the common conductor is not installed between all devices, they should be grounded according to the manufacturer's recommendations. In this case you should ground the common terminal (GND - pin 5) of the converter.

The need to use termination resistors depends on the total length of the communication bus and the communication speed configured.

USB-i485 Converter has internal termination resistors, which can be connected by including the dotted connections shown in the figure above.

For more information on termination resistors, see the document *RS485 and RS422 Basic Concepts*, available on our website www.novusautomation.com.

6.3 RS422

The connection already described for RS485 Full Duplex (4-wire) meets the RS422 interface specifications. Use this connection method to apply the **USB-i485 Converter** in an RS422 communication system.

7. LED OPERATION

USB-i485 Converter has two LEDs:

- **TX LED:** Lights up when transmitting data to the RS485/RS422 bus.
- **RX LED:** Lights up when receiving data over the RS485/RS422 bus.

If there is a contact problem or the bus wires are reversed during connection, it is possible that one of the LEDs will be constantly on. If this happens, you should check the wire connection.

8. CONFLICTS WITH OTHER USB DEVICES IN WINDOWS

In some cases, there may be a conflict with other USB device on the computer (mouse or other Serial/USB devices, for example) when you are installing the USB driver for **USB-i485 Converter**. In this case, follow the procedures below to try to restore normal operation of the affected device: Go to the Windows Control Panel and access the **USB-i485 Converter** properties:

Control Panel → System → Hardware → Device Manager → Ports (COM & LPT)

Select the desired "USB Serial Port" device, click with the right mouse button and select "Properties". Select "Port Settings" tab and click on the "Advanced" button. Uncheck the "Serial Enumerator" option:



Figure 8 – Serial Enumerator

9. TECHNICAL SPECIFICATIONS

Computer Interface	USB V1.1 Plug and Play
Operational system virtual serial port driver	Windows®; MAC; Linux.
Field Interfaces	RS485 Half Duplex (dual buses) RS485 Full Duplex RS422
Data Rate	From 300 bps to 250 kbps.
Maximum RS485/RS422 cable length	1200 m
Maximum number of devices in the RS485 network	Maximum number of devices in the RS485 network (unit load devices – 12 k Ω): <ul style="list-style-type: none"> • Half Duplex: 2 x 32 devices • Full Duplex: 32 devices
Power	From the USB port. Consumption: <100 mA.
Isolation	1500 Vcc (1 minute) from USB interface and the RS485/RS422 interface.
RS485/RS422 bus protection	\pm 60 Vcc, 15 kV ESD
USB Connection	Mini-B connector. A 1.5 m cable with plugs mini-B and A is provided with the device.
RS485/422 Connector	Screw terminal type accepting 1.5 mm ² (16 AWG) wires.
Operating Environment	0 to 50 °C, 10 to 90 % relative humidity, non-condensing.
Communication protocol	Jumper selected RS485 / RS422.
Flow Control	Automatic flow control for RS485 Half Duplex.
Internal Terminating Resistors	120 Ohms internal resistors termination enabled by jumpers.
LEDs	Transmission and reception of data.
ABS Housing	70 x 60 x 18 mm.
Certifications	CE

Table 2 – Technical Specifications

9.1 CERTIFICATIONS

CE Mark

This is a Class A product. In a domestic environment, this product may cause radio interference in which case the user may be required to take adequate measures.